

## 1" TWEETER

### SPECIAL FEATURES:

- FABRIC DIAPHRAGM
- MAGNETIC FLUID
- "BUTTERFLY" VOICE COIL ASSEMBLY
- MAGNETIC SHIELDED / DOUBLE MAGNET
- PREPARED FOR CUSTOMIZED FRONT

NOMINAL IMPEDANCE	6 $\Omega$
VOICE COIL RESISTANCE	4.6 $\Omega$
NOMINAL POWER (IEC 268-5)	80 W <sup>1)</sup>
SHORT TERM MAX. POWER (IEC 268-5)	900 W <sup>2)</sup>
LONG TERM MAX. POWER (IEC 268-5)	400 W <sup>3)</sup>
OPERATING POWER	3.2 W
SENSITIVITY (1W, 1m) / (2.83V, 1m)	91/92 dB
FREQUENCY RANGE	3-30 kHz
FREE AIR RESONANCE	1450 Hz
VOICE COIL DIAMETER	26 mm
VOICE COIL HEIGHT	1.6 mm
AIR GAP HEIGHT	2 mm
EFFECTIVE DIAPHRAGM AREA	7.1 cm <sup>2</sup>
MOVING MASS (incl. air)	0.33 g
MAGNET WEIGHT (2 magnets) (15.2 oz)	432 g
FORCE FACTOR, BxI	3.7 Txm
Qms	0.93
Qes	1.01
Qts	0.48

## D26SG-05-06

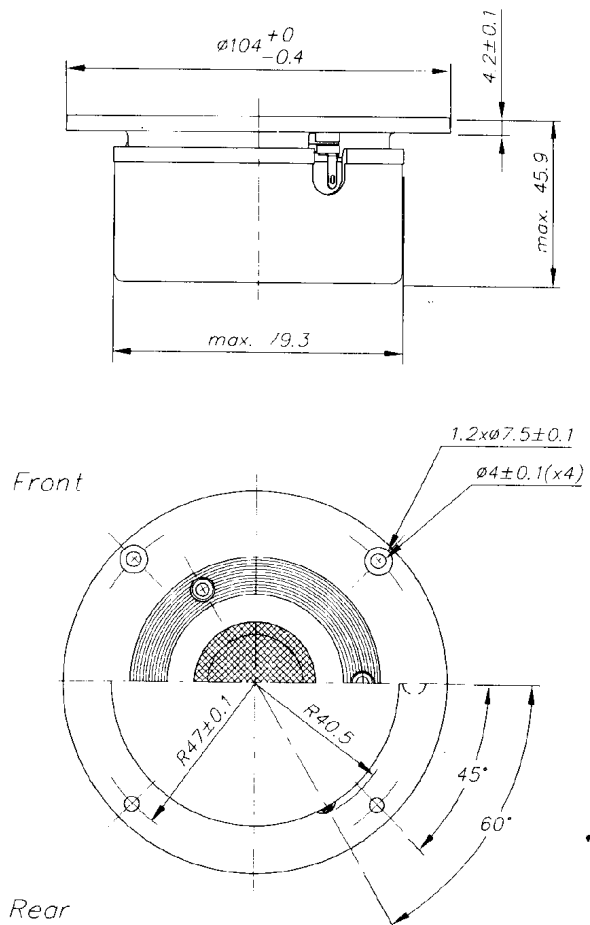

## D26SG-05-06

DISPERSION PLOT  
0, 30 and 60 deg.

Input: 2.83 V  
Mic.: 1 m

Mounted in  
infinite baffle.

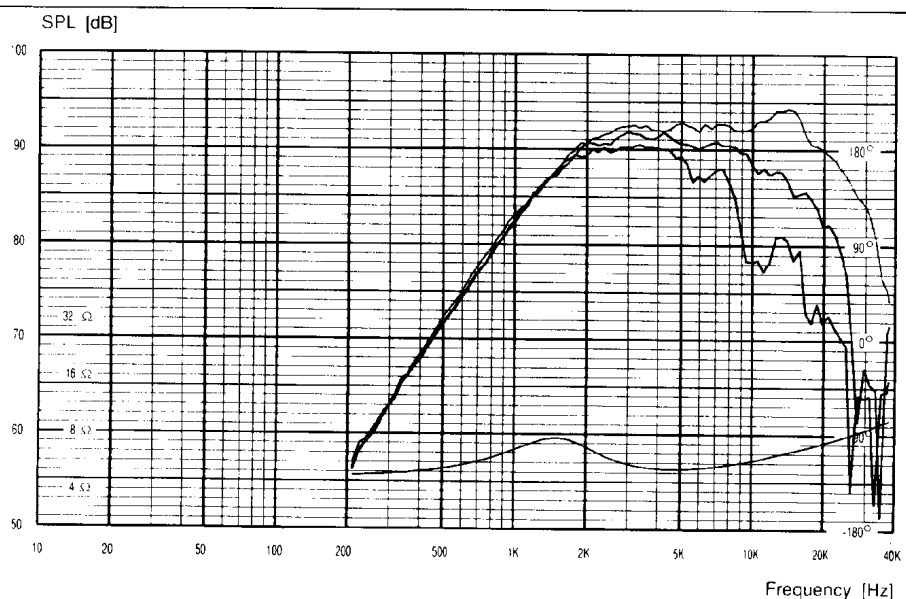

Anechoic room 6x7x8 meters.  
Half space free-field above 100 Hz.  
Brüel & Kjær 2012 Audio Analyzer.

# D26SG-05-06

# Applications

Recommended cross over:

Nom. power [W]	Fc [Hz]	L [mH]	C [ $\mu$ F]
80	3500	0.44	5.6

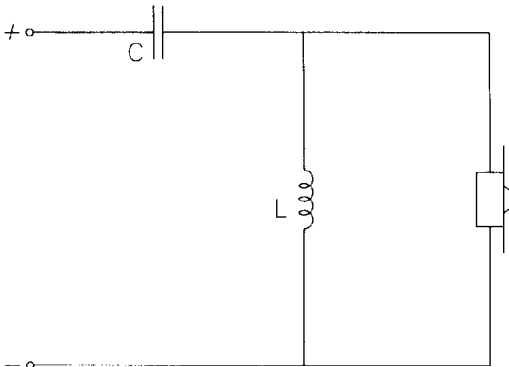

Magnetic Stray Field (3 Gauss limit):

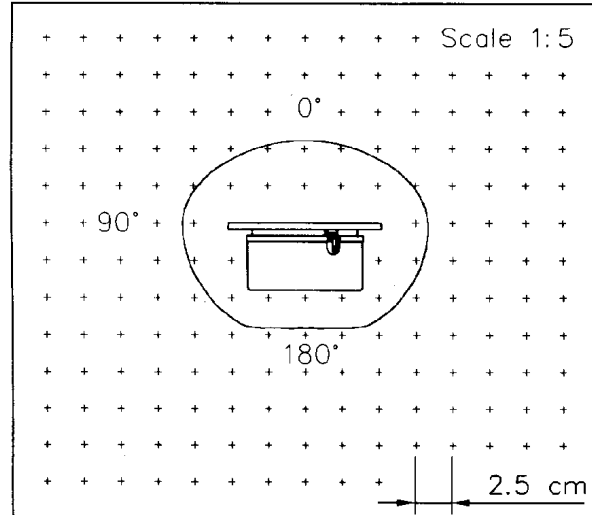

Distance to 3 Gauss limit.  
 0° : 5.6 / (2.2) cm / (inch.) from top of front.  
 90° : 8.2 / (3.2) cm / (inch.) from center of front.  
 180° : 7.2 / (2.8) cm / (inch.) from top of front.

It is recommended to use at least 2'nd order (12dB/oct) cross over for this drive unit. The load provided by the cross over should be as low as possible at the tweeter res. frequency. This will ensure maximum electrical damping, and consequently minimum excursion. This is essential for high power input. The circuit shown is the one used for the power handling tests.

Note 1-3) Power test conditions: Amb. temp. 21°C ± 3°C. Note 1) 100 hours continuous.  
 Note 2) Signal 1 sec., pause 1 min., repeated 60 times. Note 3) Signal 1 min., pause 2 min., repeated 10 times.

## CUMULATIVE SPECTRAL DECAY PLOT

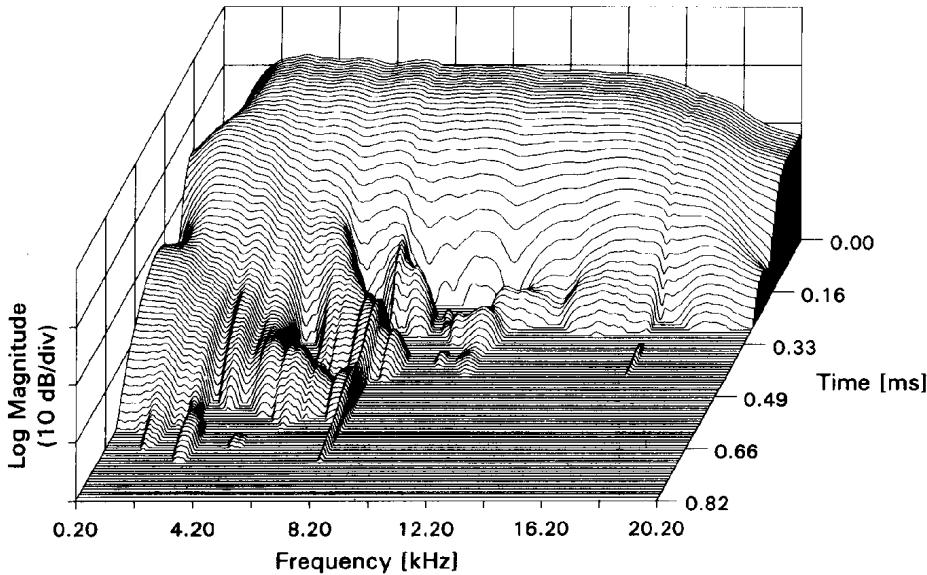

MLS impulse response  
 Samp. freq.: 120 kHz  
 Time window: 5 ms  
 Mic. distance: 0.15 m  
 Conditions:  
 Infinite baffle